

# HAUG Ionization - Installation of ionizing systems in folding machines

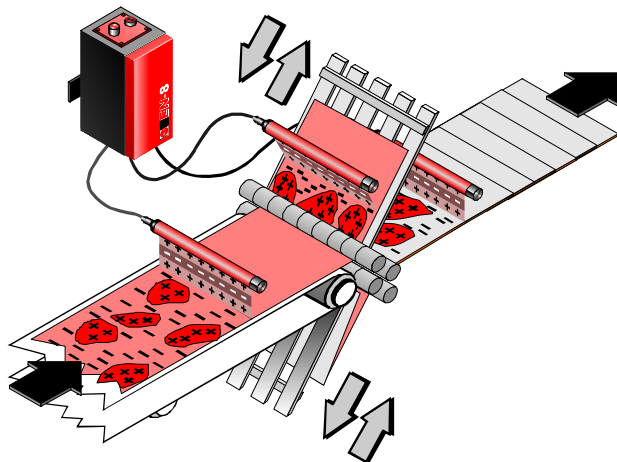

The HAUG ionizing package for folding machines is designed to eliminate electrostatic charges from the sheets to be folded. The package consists of a power supply unit, ionizing bars, high-tension cables and holders.



## Installing the power supply unit

The power supply unit can be installed anywhere and in any position. Connect the power supply unit as described in the installation instructions. The power supply unit has an input cable for connection to a grounded mains socket by means of a standard plug. It can be positioned beneath the folding unit at the appropriate folding-machine station. Always comply with the enclosed operating instructions.

## Installing the ionizing bars

A standard ionizing package for folding machines has three ionizing bars for the following standard positions

- A** in front of the sheet feeder to the first folding pocket or in the front of the feed to the folding unit
- B** on the folding pocket
- C** the third ionizing bar can be installed at a variety of positions:
  - at the exit from the folding unit or above the shaft of the roller table, in front of the feed to the next folding station, or above the exit to the delivery.

The most satisfactory results are obtained with two ionizing bars, one installed at position **A** and one at position **B**.

## Installing ionizing bars at positions A and C

At these points folding machines have shafts ( $\varnothing$  20 mm), tie bars 20 x 20 mm or tie-angles (of the sheet guide elements) crosswise to the direction of sheet feed.  
 Mount bar holders 10.0268.000 or Klick-Zack holders 10.0004.000 on the chrome-plated caps of the ionizing bars. Mount holders 10.0268.000 on shaft ( $\varnothing$  20 mm), and holders 10.0014.000 on tie-bar (20 x 20 mm) or tie-angle. Spacing corresponding to bar length or the length of the holders secured to the end caps. Connection by means of braces X-0404 (large), X-0267 (small) or slotted plate X-0422.  
 Clearance between ionizing bar and sheet at **A**: ~ 5 – 10 mm above guide element upper edge of ball cage.  
 Clearance between ionizing bar and sheet at **C**: ~ 30 mm above sheet.  
 Turn the ionizing bar in the holders until the ionizing needles are at right angles to the sheet. Seat the angled plug of the HT-cable in the socket of the ionizing bar and hand-tighten the securing screws.

## Installation on a shaft at the exit of a folding pocket

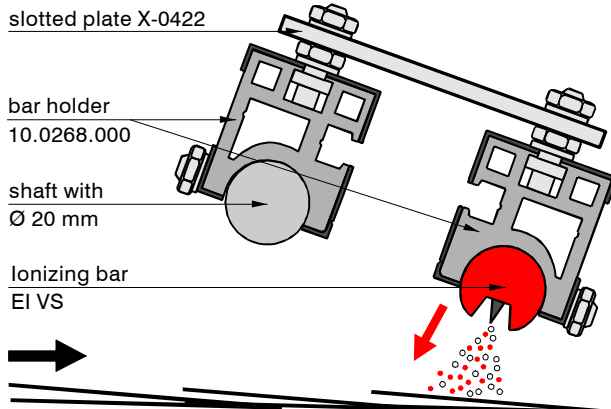

## Installation of a tie-bar

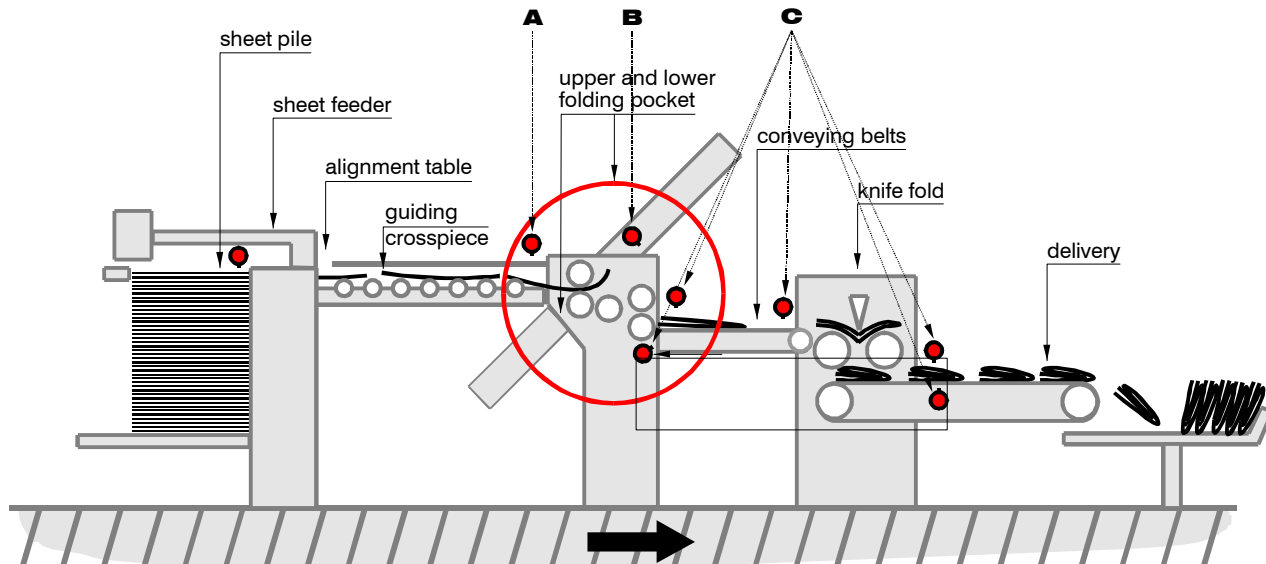
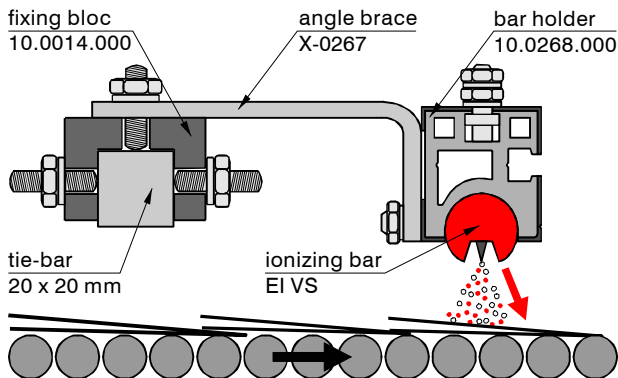

### Installation at position B

Clamp clip-on holders 10.0268.000 to the guiding elements of the folding pocket at a distance corresponding to the length of the ionizing bars. Position directly behind the point where the sheets exits the folding unit.

The distance between ionizing bar and sheet is determined by clip-on holder 10.0268.000 on the guiding elements of the folding pocket. Secure the ionizing bar in the holders in such a way that the ionizing needles are at right angles to the guiding elements. Seat the angled plug of the HT lead in the socket of the ionizing bar and hand-tighten the securing screws.

**Caution! The tips of the ionizing needles must not under any circumstances come into direct contact with metallic guides or machine components.**

### Installing on a folding pocket

ionizing bar EI VS

bar holder with special clip for folding pocket  
10.0301.004

folding pocket guiding element

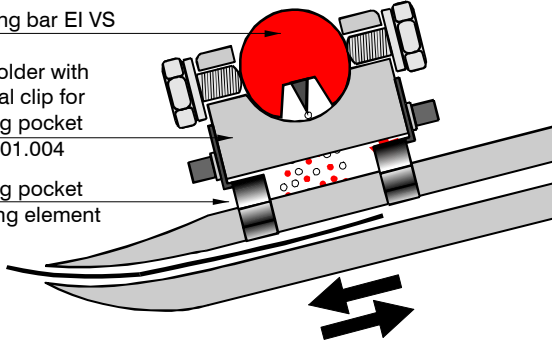

### Connecting the power supply unit

See enclosed operating instructions. Connect the straight plugs of the connecting cables to the sockets on the power supply unit and hand-tighten the securing screws. Start up the ionizing system in accordance with the operating instructions.

**Caution! Never connect or disconnect HT-cables while the ionizing system is under voltage.**

### Maintenance of the ionizing bars

Paper dust and printing powder form deposits on the ionizing bar. This pollution tends to impair performance. Do not use solvents or liquids not recommended by HAUG. We recommend cleaning with cleaning brush No. 7218 and special cleaning agent No. 7220. We strongly recommend cleaning the ionizing bars every week.

### Checking operation

The HAUG Multicheck (special accessory) can be used to ensure that the ionizing bars and the power supply unit are in correct working order.

### Troubleshooting checklist

Problem	Possible Solution
sheets not correctly singled on feeder	ionized blowing air to boost the separating-air effect, use two or four ring-ionizers
sheets are at an angle on the alignment table between feeder and station 1	install one ionizing bar at the leading edge of the alignment table
sheet does not slip all the way into the folding pocket	install one ionizing bar in front of feed into the folding unit and one on the folding pocket
even with ionizing bar installed at folding pocket, sheet does not slip all the way into the pocket	install a second ionizing bar (midway along infeed)
one bar in front of feed and two bars on the pocket, but sheet does not slip all the way into the pocket	reduce folding-unit pressure to minimum, reduce speed
above measures implemented, but no improvement or improvement negligible	remove each second top pocket rod
sheets are angled on the roller table	one ionizing bar at the exit from the former folding unit
sheets wrap round the rollers of the roller table	one ionizing bar at the exit from the former folding unit
folded sheets sticking to each other on the discharge and are difficult to stack	one ionizing bar at the exit of the last folding unit



## Problems with electrostatic charges in folding machines

The basic ionizing system for a folding machine consists of three HAUG EI VS ionizing bars. The standard positions for the three bars are:

- in front of the feed to the folding unit
- on the folding pocket
- at the exit from the folding unit

Positioned this way, the ionizing bars will eliminate most of the problems caused by electrostatic charge in folding machines. Bear in mind, however, that numerous factors influence the level of electrostatic build-up and the aggregate effect of these factors can cause difficulties even despite a correctly installed, connected and fully functional ionizing system. These factors are listed in order of importance below. Some of these factors are non-variables which users can influence only to a very limited extent, if at all. Others are variables which can be changed step by step.

#### Non-variable factors:

- paper quality (moisture content, stability, surface, etc.)
- relative humidity
- room temperature
- temperature and moisture in the air for the feeder
- dwell time of the sheets in the feeder air jet

#### Variable factors:

- positions of the ionizing bars (operator)
- extension of the existing ionizing system (operator)
- setting of the folding roller pressure (operator)
- machine speed (operator)
- conductivity of the folding roller surface (works technician)
- number of folding-pocket rods (operator)
- conductivity of the folding-pocket rods (works technician)

The variable factors, moreover, can be subdivided into those which the operator can influence and those which require the attention of the works technician. It would, of course, be impractical to call on the assistance of the works technician in every instance because of the high cost factor involved. Consequently, it is more important to concentrate on the factors that can be influenced by the operator.

The checklist below is optimised for a pocket-type folding machine. It lists typical problems and possible solutions. The examples are arranged in a sequence corresponding to the paper flow through the machine, starting with the feeder and ending at the delivery. The conditions in the various folding units (stations) 1, 2, 3, and so on are identical, and the same applies to pockets 1 (top), 2 (bottom), 3 (top), etc.

**HAUG GmbH & Co. KG**

Friedrich-List-Str. 18  
D-70771 Leinf.-Echterdingen  
Phone: +49 711 / 94 98-0  
Telefax: +49 711 / 94 98-298

**Germany**

[www.haug.de](http://www.haug.de)  
E-mail: [info@haug.de](mailto:info@haug.de)

**HAUG Biel AG**

Johann-Renfer-Str. 60  
CH-2500 Biel-Bienne 6  
Phone: +41 32 / 344 96 96  
Telefax: +41 32 / 344 96 97

**Switzerland**

[www.haug-ionisation.com](http://www.haug-ionisation.com)  
E-mail: [info@haug-biel.ch](mailto:info@haug-biel.ch)

